

# Slimdrive SL NT

## Product family

EN Pre-installation instructions

192348-02



# Contents

1	Introduction.....	3
1.1	Symbols and illustrations.....	3
1.2	Revisions and validity.....	3
1.3	Product liability.....	3
1.4	Reference documents.....	3
2	Fundamental safety precautions .....	4
2.1	Intended use.....	4
2.2	Safety instructions .....	4
2.3	Safety-conscious working .....	5
2.4	Environmentally conscious working.....	5
2.5	Safety instructions related to transportation and storage .....	5
2.6	Qualification .....	5
3	About this document.....	6
4	Overview.....	6
4.1	Diagrams.....	6
4.2	Tools and aids.....	6
4.3	Torques.....	6
4.4	Components and assembly groups.....	7
4.5	Bill of material VP-Kit.....	7
5	Pre-mounting.....	8
5.1	Machining the track and cover .....	8
5.2	Preparing the track .....	8
5.3	Mounting the stop buffers.....	8
5.4	Connecting the contact on the tooth belt lock (optional).....	9
5.5	Mounting the module mount.....	9
5.6	Mounting cable guides .....	10
5.7	Connecting motor gear unit and control unit .....	11
5.8	Pre-positioning the pre-mounted module mount, left and right.....	12
5.9	Connecting transformer and control unit.....	12
5.10	Connecting the tooth belt locking mechanism (optional) and control unit.....	14
5.11	Installing transformer earthing .....	15
5.12	Connecting rechargeable battery and control unit .....	16
6	Device safety test and production test.....	16
6.1	Unplugging the cables.....	17
7	Preparation for installation.....	17
7.1	Processing the cover for tooth belt locking mechanism (optional) .....	17
7.2	Mounting the suspension pieces .....	18
7.3	Installing the cover earthing .....	19
7.4	Installing the side panels .....	19



# 1 Introduction

## 1.1 Symbols and illustrations

### Warning notices



In these instructions, warning notices are used to warn against material damage and injuries.

- ▶ Always read and observe these warning notices.
- ▶ Observe all measures marked with the warning symbol and warning word.

Warning symbol	Warning word	Meaning
	<b>DANGER</b>	Danger to persons. Non-compliance will result in death or serious injuries.
	<b>WARNING</b>	Danger to persons. Non-compliance can result in death or serious injuries.
	<b>CAUTION</b>	Danger to persons. Non-compliance can result in minor injuries.

### Further symbols and illustrations

Important information and technical notes are highlighted to explain correct operation.

Symbol	Meaning
	means "important note". Information to prevent property damage, to understand or optimise the operation sequences.
	means "additional Information"
▶	Symbol for an action: This means you have to do something. ▶ If there are several actions to be taken, keep to the given order.

## 1.2 Revisions and validity

Version 02: valid for Slimdrive SL NT product family from model year 2021.

## 1.3 Product liability

In compliance with the liability of the manufacturer for his products as defined in the German "Product Liability Act", compliance with the information contained in this brochure (product information and intended use, misuse, product performance, product maintenance, obligations to provide information and instructions) must be ensured. Failure to comply releases the manufacturer from his statutory liability.

## 1.4 Reference documents

Type	Name
Wiring diagram	Automatic sliding doors DCU1-NT/DCU1-2M-NT
Additional wiring diagram	Automatic sliding doors DCU1-2M-NT, door controller DCU1-2M-NT for automatic sliding doors on escape routes, FR-variants DUO, LL, RWS
User manual	Automatic sliding door systems
Faults and corrective measures	DCU1-NT/DCU1-2M-NT electronic drive for automatic sliding doors
Cable plan	Automatic sliding door systems
Safety analysis	Automatic sliding doors
Installation instructions	Slimdrive SL NT product family
Additional installation instructions	Rod locking

These documents are subject to change. Use only the most recent version.

## 2 Fundamental safety precautions



GEZE GmbH is referred to as GEZE below.

### 2.1 Intended use

The sliding door system is used for the automatic opening and closing of a building passage.

The sliding door system may only be used in a vertical installation position and in dry rooms within the permitted application area.

The sliding door system is designed for pedestrian traffic in buildings.

The sliding door system is not designed for the following uses:

- for industrial use
- for area of application which do not serve pedestrian traffic (such as garage doors)
- on mobile objects such as ships

The sliding door system may only be used:

- in the modes of operation provided for by GEZE
- with the components approved/released by GEZE
- with the software delivered by GEZE
- in the installation variants / types of installation documented by GEZE
- within the tested/approved area of application (climate / temperature / IP rating)

Any other use is considered non-intended and will lead to the exclusion of all liability and warranty claims to GEZE.

### 2.2 Safety instructions

- Intervention and modifications which influence the safety technology and functionality of the sliding door system may only be carried out by GEZE.
- Problem-free and safe operation assumes proper transportation, proper set-up and installation, qualified operation and correct maintenance have taken place.
- The relevant accident prevention regulations and other generally recognised safety-related or health & safety rules must be kept.
- Only original accessories, original spare parts and accessories approved by GEZE guarantee problem-free function of the sliding door system
- The mandatory installation, maintenance and repair work must be performed by properly trained personnel authorised by GEZE.
- The country-specific laws and regulations are to be observed during safety-related tests.
- If unauthorised changes are made to the system, GEZE cannot be held liable in any way whatsoever for any resulting damage, and the statement of approval for use in escape and rescue routes is no longer valid.
- GEZE does not accept any warranty for combinations with third-party products.
- Only original GEZE parts may be used for repair and maintenance work.
- Connection to the mains voltage must be carried out by a qualified electrician or a qualified electrician for specified tasks. Perform the power connection and protective earth connection test in accordance with VDE 0100 Part 600.
- Use an on-site 10 A overload cut-out as the line-side disconnecting device.
- Protect the display programme switch against unauthorised access.
- In compliance with Machinery Directive 2006/42/EC, a risk analysis must be performed and the door system identified in accordance with CE Marking Directive 93/68/EEC before the door system is commissioned.
- Observe the latest versions of guidelines, standards and country-specific regulations, in particular:
  - DIN 18650: "Building hardware – Powered automatic doors"
  - VDE 0100, Part 600: "Installation of low-voltage systems"
  - EN 16005: "Power operated pedestrian doorsets – Safety in use – Requirements and test methods"
  - EN 60335-1: "Household and similar electrical appliances - Safety Part 1: General requirements"
  - EN 60335-2-103: "Household and similar electrical appliances - Safety: Special requirements for drives for gates, doors and windows"
- Do not loosen screwed, electric earthing connections.



The product should be installed or incorporated in such a way that effortless access to the product is guaranteed during any repairs and/or maintenance, and that any removal costs do not stand out of proportion to the value of the product.

## 2.3 Safety-conscious working

- Secure workplace against unauthorised entry.
- Use only the cables specified on the cable plan provided. Cables must be shielded in compliance with the wiring diagram.
- Secure loose, internal drive cables with cable ties.
- Before working on the electrical system:
  - Disconnect the drive from the 230 V mains and secure it against being switched back on again. Check isolation from power supply.
  - Disconnect the control unit from the 24 V rechargeable battery.
- When an Uninterruptible Power Supply (UPS) is used, the system will still be under voltage even when disconnected from the mains.
- Always use insulated wire-end ferrules for wire cores.
- Make sure of sufficient lighting.
- Danger of injury with opened drive. Hair, clothing, cables, etc. can be drawn in by rotating parts.
- Danger of injury caused by unsecured crushing, impact, drawing-in or shearing spots.
- Danger of injury due to sharp edges on the drive and door leaf.
- Danger of injury during installation through freely moving parts.

## 2.4 Environmentally conscious working

- When disposing of the door system, separate the different materials and have them recycled.
- Do not dispose of batteries and rechargeable batteries with household waste.
- Comply with the statutory regulations when disposing of the door system and the batteries/rechargeable batteries.

## 2.5 Safety instructions related to transportation and storage

- ▶ Do not throw, do not drop.
- ▶ Avoid heavy impact.
- Storage temperatures under  $-30\text{ °C}$  and above  $+60\text{ °C}$  can result in damage to the device.
- Protect against humidity.
- Dry, well ventilated, closed, weather-proof and UV-protected rooms are suitable as storage areas.

## 2.6 Qualification

Observe country-specific regulations!

Applicable in Germany:

Companies which carry out the pre-mounting of sliding door drives for escape routes must be approved as an extended production facility by the testing institute which issued the type approval certificate.

### 3 About this document

These instructions describe the pre-mounting of the automatic sliding door drives of the Slimdrive SL NT product family.

## 4 Overview

### 4.1 Diagrams

Number	Type	Name
70511-0-001	Drive drawing	GEZE Slimdrive SL NT, drives
70511-2-0200	Component drawing	Cover, bespoke
70511-2-0209	Component drawing	Track, bespoke, SL NT
70511-2-0231	Component drawing	Track, drilled, SL NT
70511-2-0281	Component drawing	Track, bespoke, SL NT 2-leaf, GGS with fixed panels
70511-2-0282	Component drawing	Track, bespoke, SL NT 1-leaf, left hand slide to open, GGS with fixed panel
70511-2-0283	Component drawing	Track, bespoke, SL NT 1-leaf, right hand slide to open, GGS with fixed panel
70511-2-0228	Component drawing	Connecting profile roller carriage
70511-1-0107	Component drawing	Module mount right, DCU1-NT, SL NT
70511-1-0108	Component drawing	Module mount right, SL NT -FR 2M/-FR DUO
70511-1-0109	Component drawing	Module mount right, SL NT -FR LL/ -FR RWS
70511-1-0106	Component drawing	Module mount left SL NT and locking mechanism
70511-1-0117	Component drawing	Module mount left, SL NT



The diagrams are subject to change without notice. Use only the most recent version.

### 4.2 Tools and aids

Tool	Size
Tape measure	
Marking pen	
Torque spanner	
Allen key	2 mm, 2.5 mm, 3 mm, 4 mm, 5 mm, 6 mm
Open-ended spanner	8 mm, 10 mm, 13 mm, 15 mm
Ring spanner	8 mm, 10 mm
Screwdriver set	Slotted up to 6 mm, cross-slot PH2 and PZ2
Torx key	Tx 20 (bit insert length at least 110 mm)
Side-cutting pliers	
Crimping pliers for cables	
Wire stripper	
Plastic bottle as tip safeguard	
Display programme switch DCU1/Service terminal ST220/GEZEconnects	

### 4.3 Torques

The torques are given at the respective installation step.

## 4.4 Components and assembly groups

These illustrations show the equipment of a standard drive in 2-leaf and 1-leaf version.

The structure of the assembly groups can vary depending on the drive equipment or version. Precise details about positioning of the individual components can be found on the drive drawing.

### 2-leaf

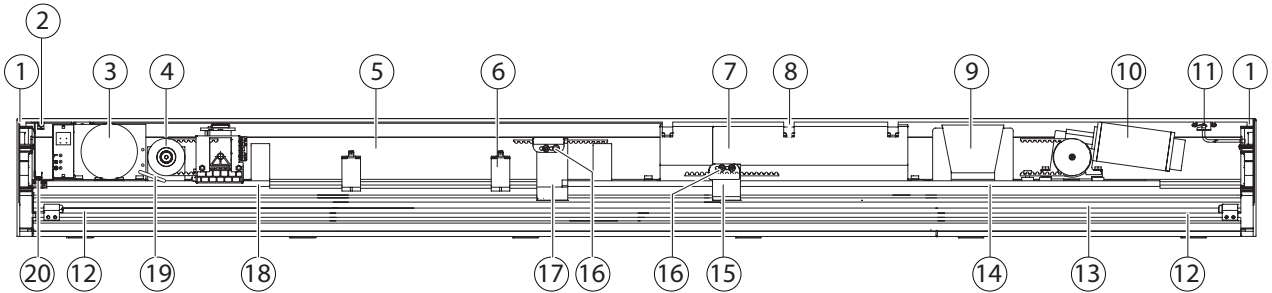

### 1-leaf, right hand slide to open

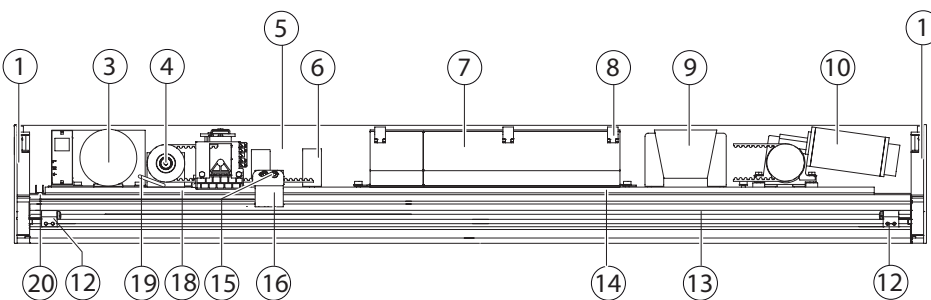

### 1-leaf, left hand slide to open

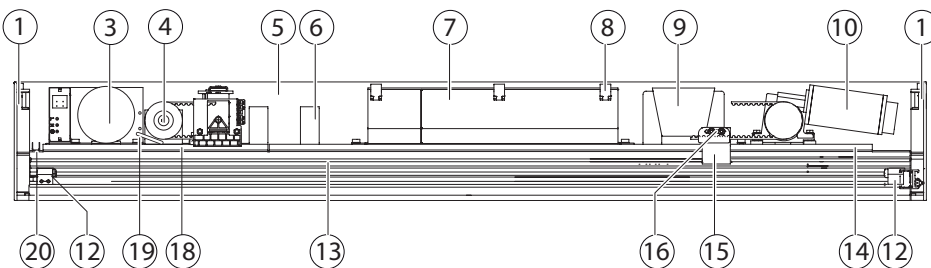

## 4.5 Bill of material VP-Kit

1	Side panel	11	Cover catch	-	Div. clear adhesive labels
2	Cover earthing	12	Stop buffer	-	Moving leaf, mounting aid
3	Transformer	13	Track	-	Accessories for fastening drive components
4	Deflection pulley	14	Module mount, right	-	Accessories for cable fastening
5	Cover	15	Belt lock	-	Accessories module mounts
6	Cable guide	16	Driver, short	-	Accessories connecting arm
7	Control unit	17	Driver, long	-	Installation instructions
8	DCU cable guide	18	Module mount, left	-	User manual
9	Rechargeable battery	19	Transformer cable	-	Wiring diagram
10	Motor gear unit	20	Transformer earthing	-	Log book
				-	Safety analysis
				-	EC Installation Declaration of Conformity
				-	Inspection certificate booklet
				-	Type test mark
				-	Drive drawing
				-	Roller carriage

## 5 Pre-mounting

The up-to-date drive drawing is applicable for the pre-mounting work to be carried out. All components must be identified and installed in accordance with the drive drawing.

### 5.1 Machining the track and cover

- ▶ Check profiles for damage.
- ▶ Cut the track and cover to the required length (see machining drawings, Chapter 4.1).
- ▶ Check whether additional fastening bore holes are necessary (see machining drawings (for bespoke track) Chapter 4.1).
- ▶ Always drill the wall attachment drill holes in pairs one above the other in the drill grooves.
- ▶ Clean the track and cover after machining.

### 5.2 Preparing the track

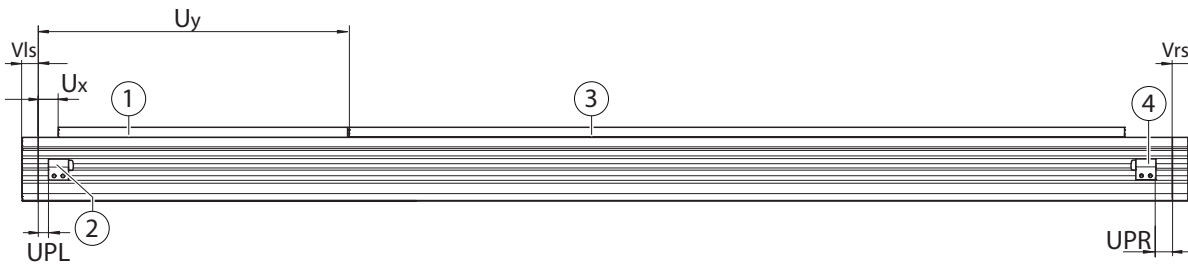

- ▶ Mark position (UPL) for stop buffer left (2) and (UPR) for stop buffer right (4) as shown on the drive drawing.
- ▶ Mark position (Ux) for module mount left (1) and (Uy) for module mount right (3) as shown on the drive drawing.

### 5.3 Mounting the stop buffers

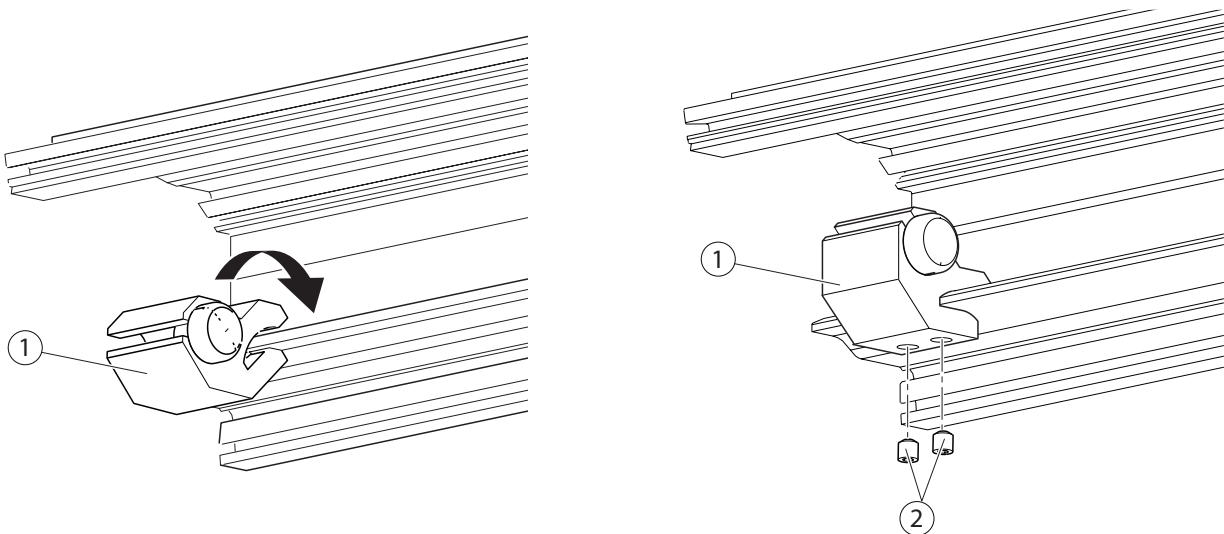

- ▶ Place the stop buffers, left and right (1) on the track and swivel them upwards.
- ▶ Screw in the setscrews M6x6 (2) until they are in contact with the track.  
Do **not** tighten the setscrews.

The exact position of the stop buffers (1) is specified during installation of the moving leaf.



## 5.4 Connecting the contact on the tooth belt lock (optional)

- ▶ Remove screws (2) on the feedback switch (1) of the tooth belt locking mechanism.
- ▶ Place the alarm contact switch (3) on the feedback switch (1).
- ▶ Fix both switches in place on the tooth belt locking mechanism using the longer screw (2) from the retrofit kit.
- ▶ Connect the cable for the tooth belt locking mechanism.
- ▶ Shorten the switching lug of the alarm contact switch.

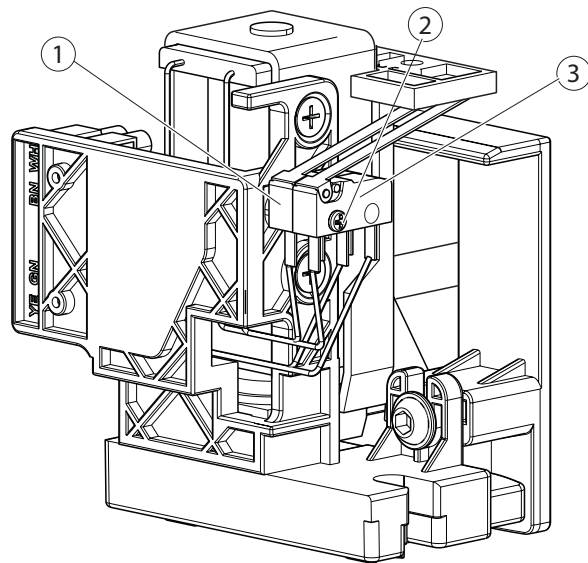

## 5.5 Mounting the module mount

### 5.5.1 Mounting the left-hand module mount

- ▶ Mount the left-hand module mount as shown in the drawing.

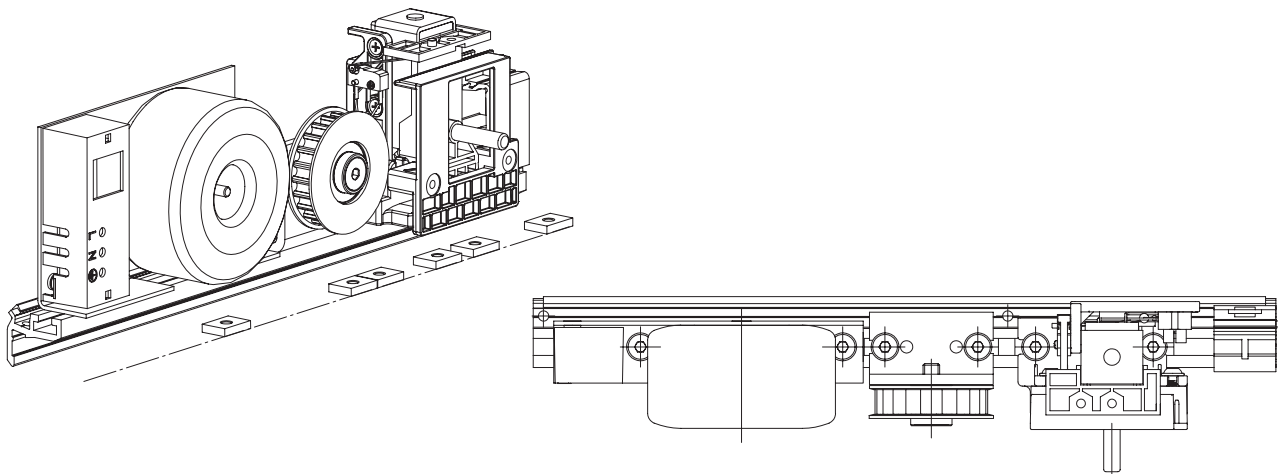

Module mount left with locking mechanism



The module mount shown here has been chosen as an example. The installation dimensions of the module mount you are using can be found on the respective component drawing (see Chapter 4.1).

- ▶ Slide the sliding blocks into the module mount.
- ▶ Mount the components with the screws provided in accordance with the drawing.
  - Tightening torque deflection pulley approx. 15 Nm
  - Tightening torque remaining components 10 Nm

### 5.5.2 Mounting the right-hand module mount

- ▶ Mount the right-hand module mount as shown in the drawing.

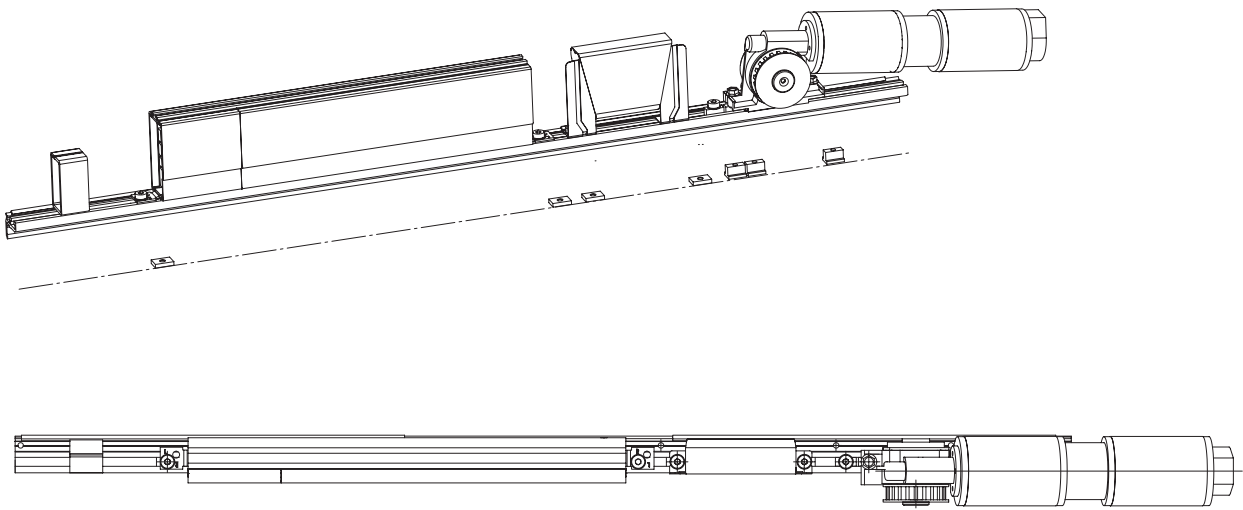

Module mount right FR/FR DUO



The module mount shown here has been chosen as an example. The installation dimensions of the module mount you are using can be found on the respective component drawing (see Chapter 4.1).

- ▶ Slide the sliding blocks into the module mount.
- ▶ Mount the components with the screws provided in accordance with the drawing.
  - Tightening torques of the components: 10 Nm.

### 5.6 Mounting cable guides



#### Cables can be cut!

- ▶ Lay cables in such a way that there are no cables near the moving parts.

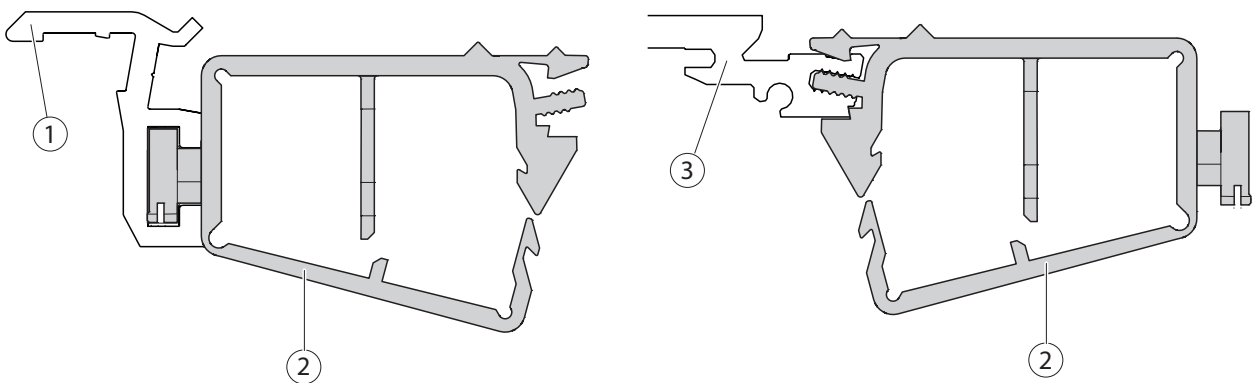

- ▶ Fix the cable guide (2) to the module mount (1) or track (3). Cable guide spacing approx. 200 mm.

## 5.7 Connecting motor gear unit and control unit

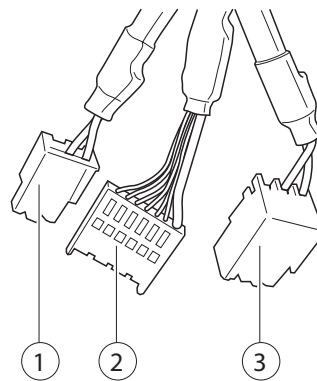

### Slimdrive SL NT

- ▶ Lay the rotary encoder cable (2) and motor connection cable (3) to the control unit.
- ▶ Insert the connector into the control unit (4).

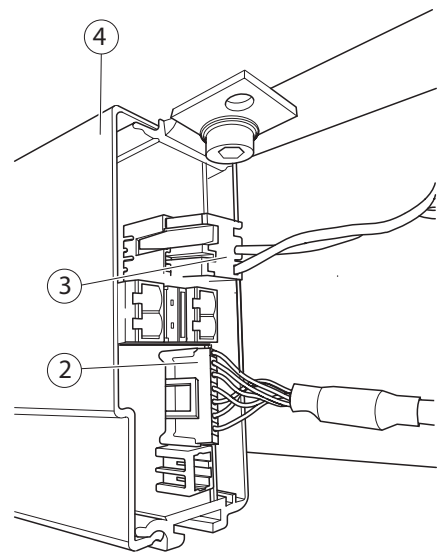

### Slimdrive SL NT-FR

- ▶ Route the rotary transducer cable (2), motor connection cable (3) and motor connection cable of the second motor gear unit (1) to control unit.
- ▶ Insert the connector into the control unit (4).

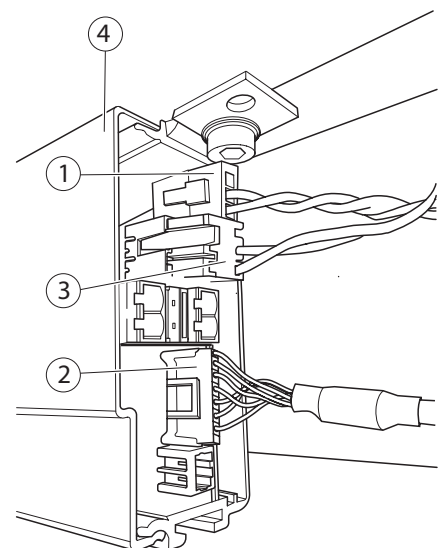

Do not plug rechargeable battery cable into the control unit yet.  
The rechargeable battery is not connected to the control unit until the production test and commissioning.

## 5.8 Pre-positioning the pre-mounted module mount, left and right

- ▶ Fix the pre-mounted module mount left (2) and right (3) with one screw each to the track (1).



### Recommendation:

- ▶ Mark the position of the module mount left (2) and right (3) on the track (1).

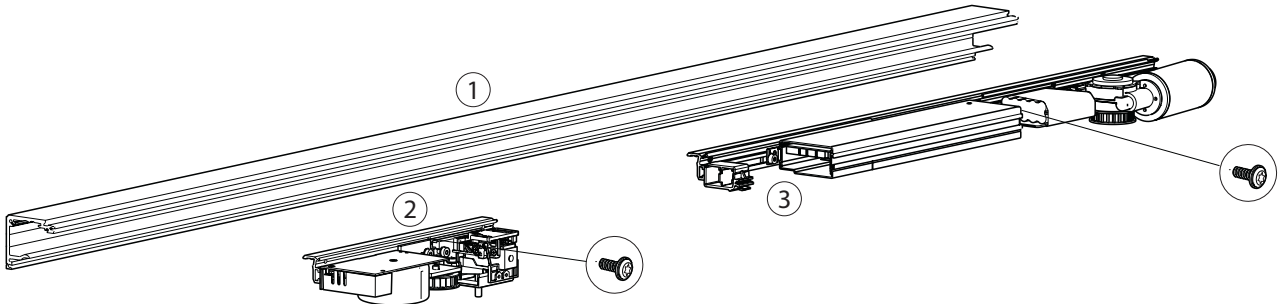

## 5.9 Connecting transformer and control unit



- ▶ Make sure that cables are shortened and laid in such a way that they do not become jammed when the cover is positioned and cannot come into contact with moving components.

- ▶ Shorten three-core cable (1).
- ▶ Strip at both ends and attach insulated wire-end ferrules.
- ▶ Attach the two connectors (3) on the control side (2).
- ▶ Insert the connectors (3) at the control unit (2).

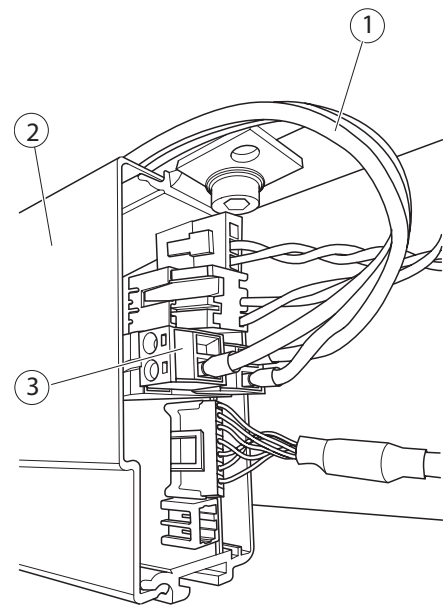

- ▶ Note earthing connection!
- ▶ Do not mix up wires!

- ▶ Fix the cable guide DCU (4) to the control unit
- ▶ Route the transformer cable (1) between the control unit (2) and module mount (5).

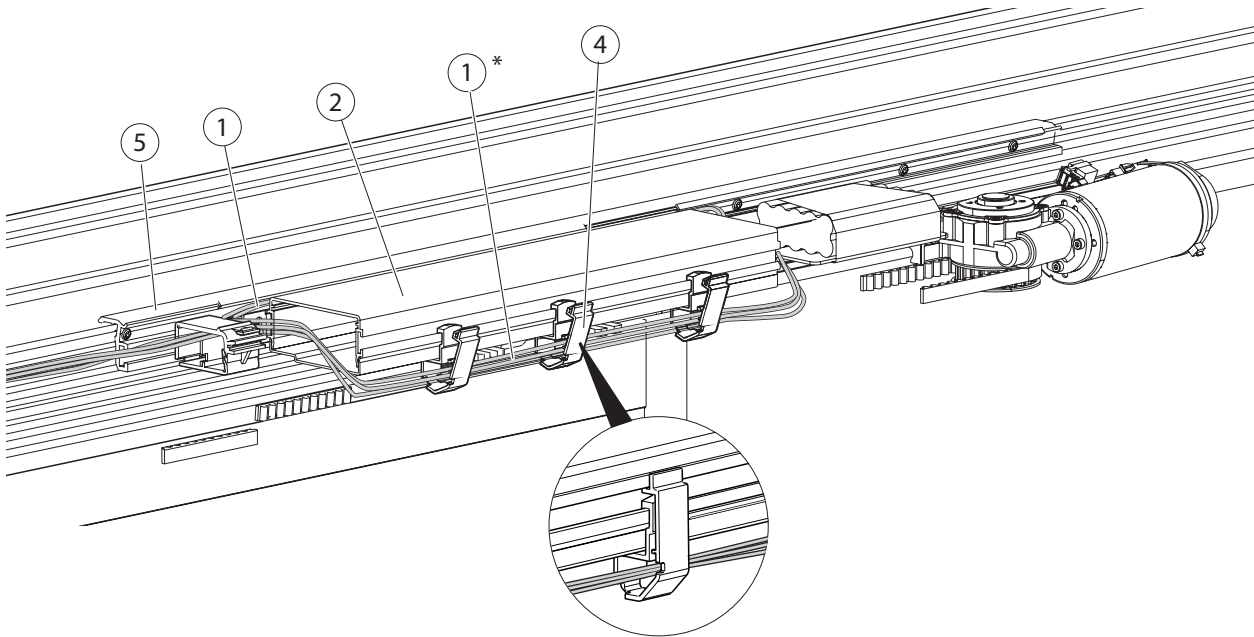

\* Alternatively, the transformer cable (1) can be fixed to the front of the control unit.

- ▶ Fit the transformer cable (1) to the terminal (6) of the transformer.

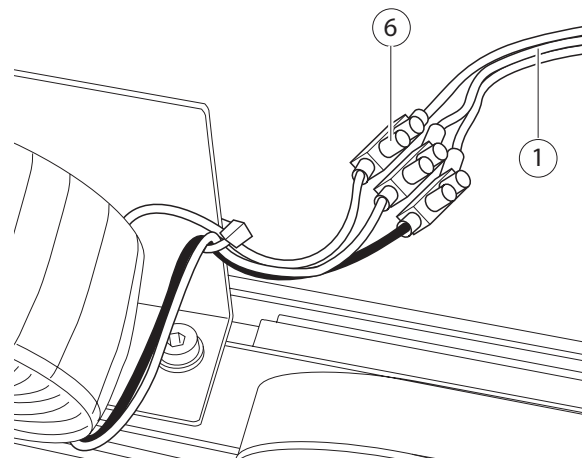

## 5.10 Connecting the tooth belt locking mechanism (optional) and control unit

- ▶ Plug the cable for tooth belt locking mechanism (1) in at the control unit (2).

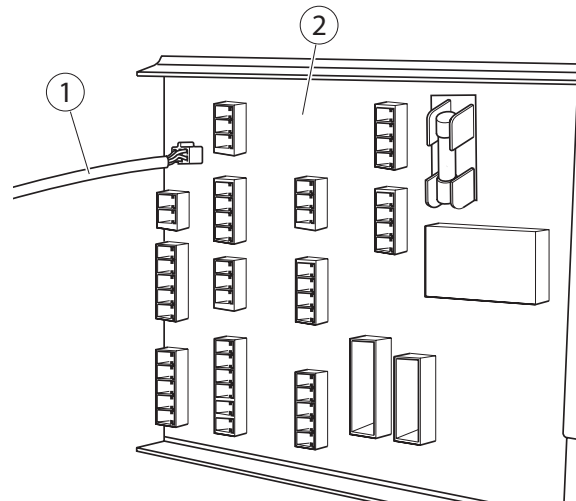

- ▶ Lay the cable for tooth belt locking mechanism (1) through the cable guide to the tooth belt locking mechanism (optional) (3), shorten if necessary, strip and attach the insulated wire-end ferrules.
- ▶ Connect the tooth belt locking mechanism as shown on the wiring diagram.

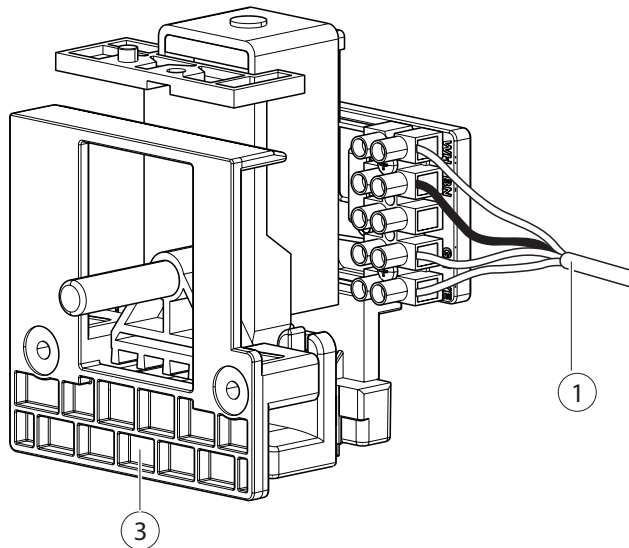

## 5.11 Installing transformer earthing



Precise details about positioning of the individual components can be found on the drive drawing.

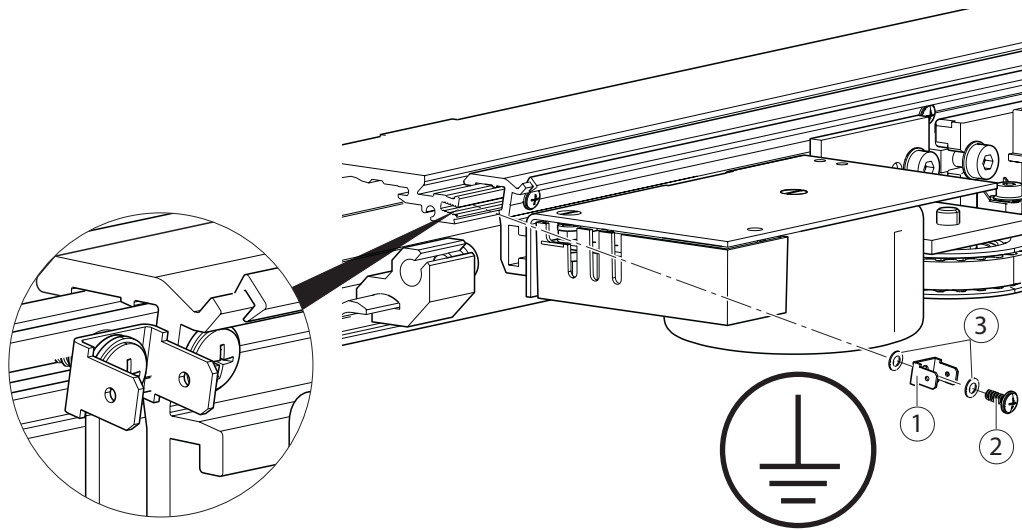

Depending on the drive length, install 1 or 2 earthing points (see drive drawing):

- next to the module mount on the left (see figure)
- and at the end of the track in addition with longer drives
- ▶ Screw the device flat plug (1) to the track (torque 3.5 Nm) using the enclosed screw (2) and the lock washer (3).
- ▶ Connect the earthing cable (4) from the transformer to the device flat plug (1).

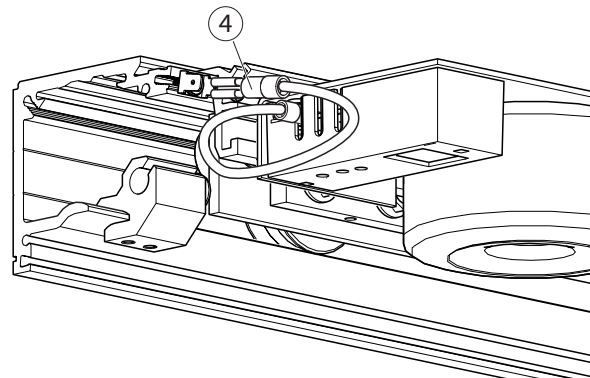

## 5.12 Connecting rechargeable battery and control unit

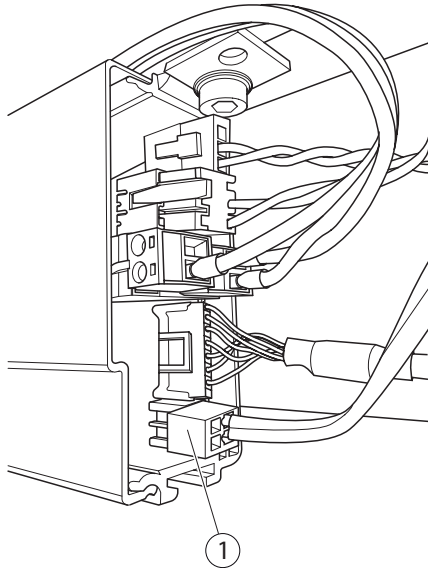

### CAUTION!

**Danger of injury due to impact and crushing!**

When the rechargeable battery cable (1) is plugged in, the pulley on the motor gear unit can move unexpectedly.

- ▶ Do not reach into the area with moving parts.

- ▶ Check whether the rechargeable battery cable (1) is long enough.
- ▶ If necessary, plug the rechargeable battery extension cable to the rechargeable battery cable.
- ▶ Lay rechargeable battery cable (1) to the control unit.
- ▶ Insert the connector into the control unit.

## 6 Device safety test and production test



### WARNING!

**Risk of fatal injury due to electric shock!**

- ▶ The electrical system (230 V/115 V) may only be connected and disconnected by a qualified electrician or a qualified electrician for specified tasks.

- ▶ Carry out device safety test in accordance with EN 60335-1 Appendix A.

The device safety test is made up of the following parts:

- Protective earth test with 10 A test current
- Dielectric strength test (high-voltage test) with 1000 VAC

The use of a test device suitable for this standard is necessary for this.

#### Test procedure

- ▶ Connect mains cable with mains plug to the transformer.
- ▶ Insert mains plug into test device.
- ▶ Start test on test device.
- ▶ Test all the metal parts connected to protective earth one after the other using the probe.  
The low-impedance connection between the PE conductor of the mains cable and the metal part contacted with the probe is checked during this process.

Contact at least the following test points with the probe:

- Metal bracket transformer
- PE connection on the secondary side of the transformer (lustre terminal)
- Track (bright, not anodised spot)
- Device flat plug for earth connection transformer
- Optional 2<sup>nd</sup> device flat plug for earth connection hood

All protective earth connections must have a resistance smaller than 0.1 Ω.



- ▶ Then start the dielectric strength test (high-voltage test) at the test device.

! Only drives which have passed the device safety test may be put into operation.

The result of the device safety test must be documented comprehensibly together with the serial number of the drive.

After the device safety test, do not disconnect the device flat plug of the earth connection from the track.

- ▶ Carry out the production test as described in the wiring diagram "Automatic sliding doors DCU1-NT/DCU1-2M-NT".

## 6.1 Unplugging the cables

i Unplugging the cables makes installation of the track on site easier.

- ▶ Unplug the rechargeable battery cable at the control unit and secure it for transport.
- ▶ Unplug the cable of the tooth belt locking mechanism at the control unit and secure it for transport.
- ▶ Disconnect the transformer cable at the lustre terminal of the transformer and secure it for transport.

## 7 Preparation for installation

During preparation for installation the drive unit is prepared for later installation. The current drive drawing is applicable for carrying out the installation work. All components must be identified and installed in accordance with the drive drawing.

### 7.1 Processing the cover for tooth belt locking mechanism (optional)

The tooth belt locking mechanism has a locking pin which can be used to unlock or lock the tooth belt manually. For this locking pin, a hole must be drilled on the cover in accordance with the following sketch.

! The position of the hole must be checked on site. Depending on the positioning of the drive components, minor deviations can occur here. GEZE thus recommends only drilling the hole on site once the exact position of the tooth belt locking mechanism is known.

i Dimensional specifications for dimension C can be found in the machining drawing for the cover.

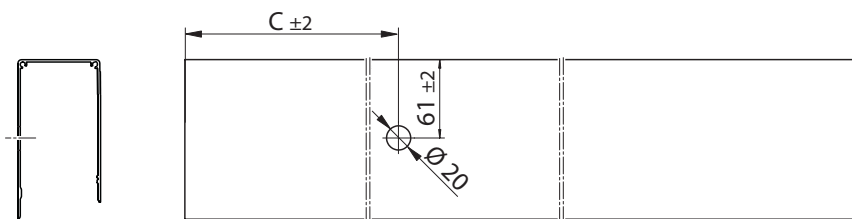

- ▶ Drill a hole  $\varnothing 20$  mm.
- ▶ Deburr the hole.

## 7.2 Mounting the suspension pieces

### 7.2.1 Mount the cover suspension piece

- ▶ Slide the cover suspension piece (1) into the upper or lower screw duct of the cover (2).

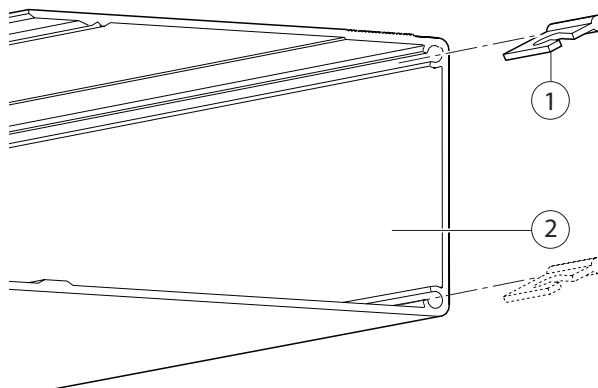

- ▶ Secure the cover suspension piece (1) on the right and left at a distance of approx. 50 mm from the end of the cover using 2 screws (tightening torque max. 1.5 Nm).

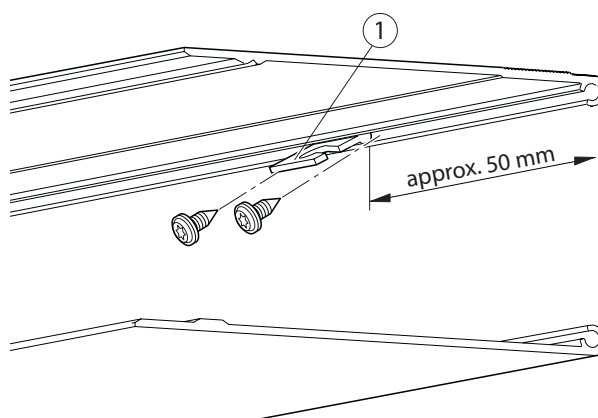

- ▶ Push the cords (rubber cables) (3) onto the mounted suspension pieces (1) of the cover.

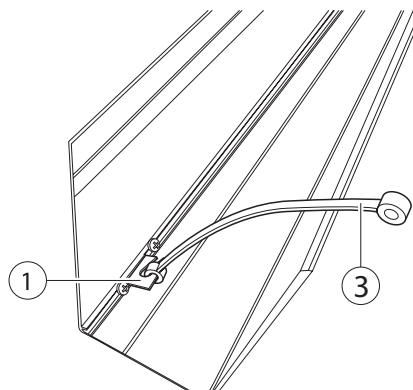

### 7.2.2 Mounting the side panel suspension piece

- ▶ Screw the side panel suspension piece (2) using the oval head screw (3) into side panels (1) left and right (tightening torque 1.5 Nm).

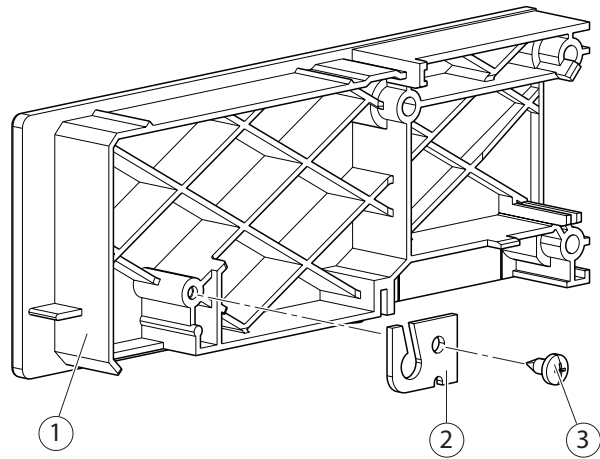

### 7.3 Installing the cover earthing

- ▶ At the left-hand end of the cover (1), knock the locating pin for the cover earthing (2) flush into the groove on the cover (1).

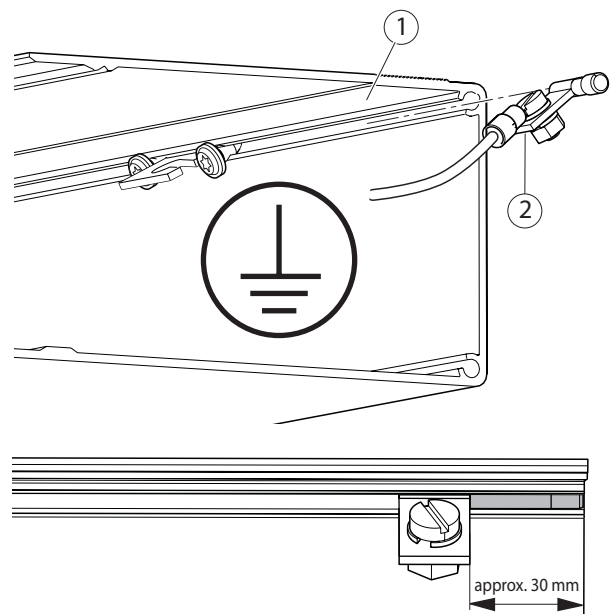

### 7.4 Installing the side panels

- ! ▶ If there is only a little space between the track and the side wall, pre-mount the side panels.

- ▶ Slide the brush (2) into the track.
- ▶ Screw the side panels (3) left and right to the track (1) using 3 screws (tightening torque 5 Nm).

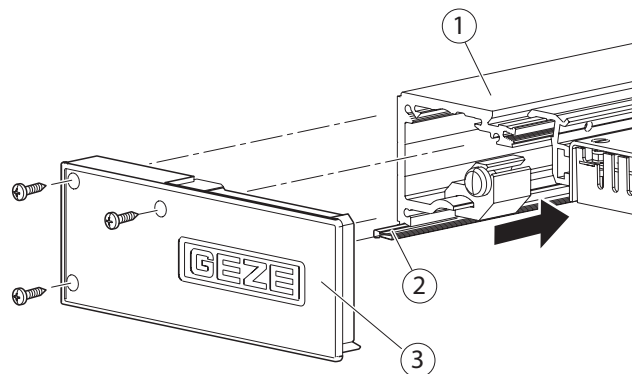

**Germany**  
GEZE GmbH  
Niederlassung Süd-West  
Tel. +49 (0) 7152 203 594  
E-Mail: leonberg.de@geze.com

GEZE GmbH  
Niederlassung Süd-Ost  
Tel. +49 (0) 7152 203 6440  
E-Mail: muenchen.de@geze.com

GEZE GmbH  
Niederlassung Ost  
Tel. +49 (0) 7152 203 6840  
E-Mail: berlin.de@geze.com

GEZE GmbH  
Niederlassung Mitte/Luxemburg  
Tel. +49 (0) 7152 203 6888  
E-Mail: frankfurt.de@geze.com

GEZE GmbH  
Niederlassung West  
Tel. +49 (0) 7152 203 6770  
E-Mail: duesseldorf.de@geze.com

GEZE GmbH  
Niederlassung Nord  
Tel. +49 (0) 7152 203 6600  
E-Mail: hamburg.de@geze.com

GEZE Service GmbH  
Tel. +49 (0) 1802 923392  
E-Mail: service-info.de@geze.com

**Austria**  
GEZE Austria  
E-Mail: austria.at@geze.com  
www.geze.at

**Baltic States –**  
Lithuania / Latvia / Estonia  
E-Mail: baltic-states@geze.com

**Benelux**  
GEZE Benelux B.V.  
E-Mail: benelux.nl@geze.com  
www.geze.be  
www.geze.nl

**Bulgaria**  
GEZE Bulgaria - Trade  
E-Mail: office-bulgaria@geze.com  
www.geze.bg

**China**  
GEZE Industries (Tianjin) Co., Ltd.  
E-Mail: chinasales@geze.com.cn  
www.geze.com.cn

GEZE Industries (Tianjin) Co., Ltd.  
Branch Office Shanghai  
E-Mail: chinasales@geze.com.cn  
www.geze.com.cn

GEZE Industries (Tianjin) Co., Ltd.  
Branch Office Guangzhou  
E-Mail: chinasales@geze.com.cn  
www.geze.com.cn

GEZE Industries (Tianjin) Co., Ltd.  
Branch Office Beijing  
E-Mail: chinasales@geze.com.cn  
www.geze.com.cn

**France**  
GEZE France S.A.R.L.  
E-Mail: france.fr@geze.com  
www.geze.fr

**Hungary**  
GEZE Hungary Kft.  
E-Mail: office-hungary@geze.com  
www.geze.hu

**Iberia**  
GEZE Iberia S.R.L.  
E-Mail: info.es@geze.com  
www.geze.es

**India**  
GEZE India Private Ltd.  
E-Mail: office-india@geze.com  
www.geze.in

**Italy**  
GEZE Italia S.r.l. Unipersonale  
E-Mail: italia.it@geze.com  
www.geze.it

GEZE Engineering Roma S.r.l.  
E-Mail: italia.it@geze.com  
www.geze.it

**Korea**  
GEZE Korea Ltd.  
E-Mail: info.kr@geze.com  
www.geze.com

**Poland**  
GEZE Polska Sp.z o.o.  
E-Mail: geze.pl@geze.com  
www.geze.pl

**Romania**  
GEZE Romania S.R.L.  
E-Mail: office-romania@geze.com  
www.geze.ro

**Russia**  
OOO GEZE RUS  
E-Mail: office-russia@geze.com  
www.geze.ru

**Scandinavia – Sweden**  
GEZE Scandinavia AB  
E-Mail: sverige.se@geze.com  
www.geze.se

**Scandinavia – Norway**  
GEZE Scandinavia AB avd. Norge  
E-Mail: norge.se@geze.com  
www.geze.no

**Scandinavia – Denmark**  
GEZE Danmark  
E-Mail: danmark.se@geze.com  
www.geze.dk

**Singapore**  
GEZE (Asia Pacific) Pte, Ltd.  
E-Mail: gezesea@geze.com.sg  
www.geze.com

**South Africa**  
GEZE South Africa (Pty) Ltd.  
E-Mail: info@gezesa.co.za  
www.geze.co.za

**Switzerland**  
GEZE Schweiz AG  
E-Mail: schweiz.ch@geze.com  
www.geze.ch

**Turkey**  
GEZE Kapı ve Pencere Sistemleri  
E-Mail: office-turkey@geze.com  
www.geze.com

**Ukraine**  
LLC GEZE Ukraine  
E-Mail: office-ukraine@geze.com  
www.geze.ua

**United Arab Emirates/GCC**  
GEZE Middle East  
E-Mail: gezeme@geze.com  
www.geze.ae

**United Kingdom**  
GEZE UK Ltd.  
E-Mail: info.uk@geze.com  
www.geze.com

**GEZE GmbH**  
Reinhold-Vöster-Straße 21–29  
71229 Leonberg  
Germany

Tel.: 0049 7152 203 0  
Fax.: 0049 7152 203 310  
www.geze.com

